

# SERIES 50 VL-TYPE

## VALVE GATE

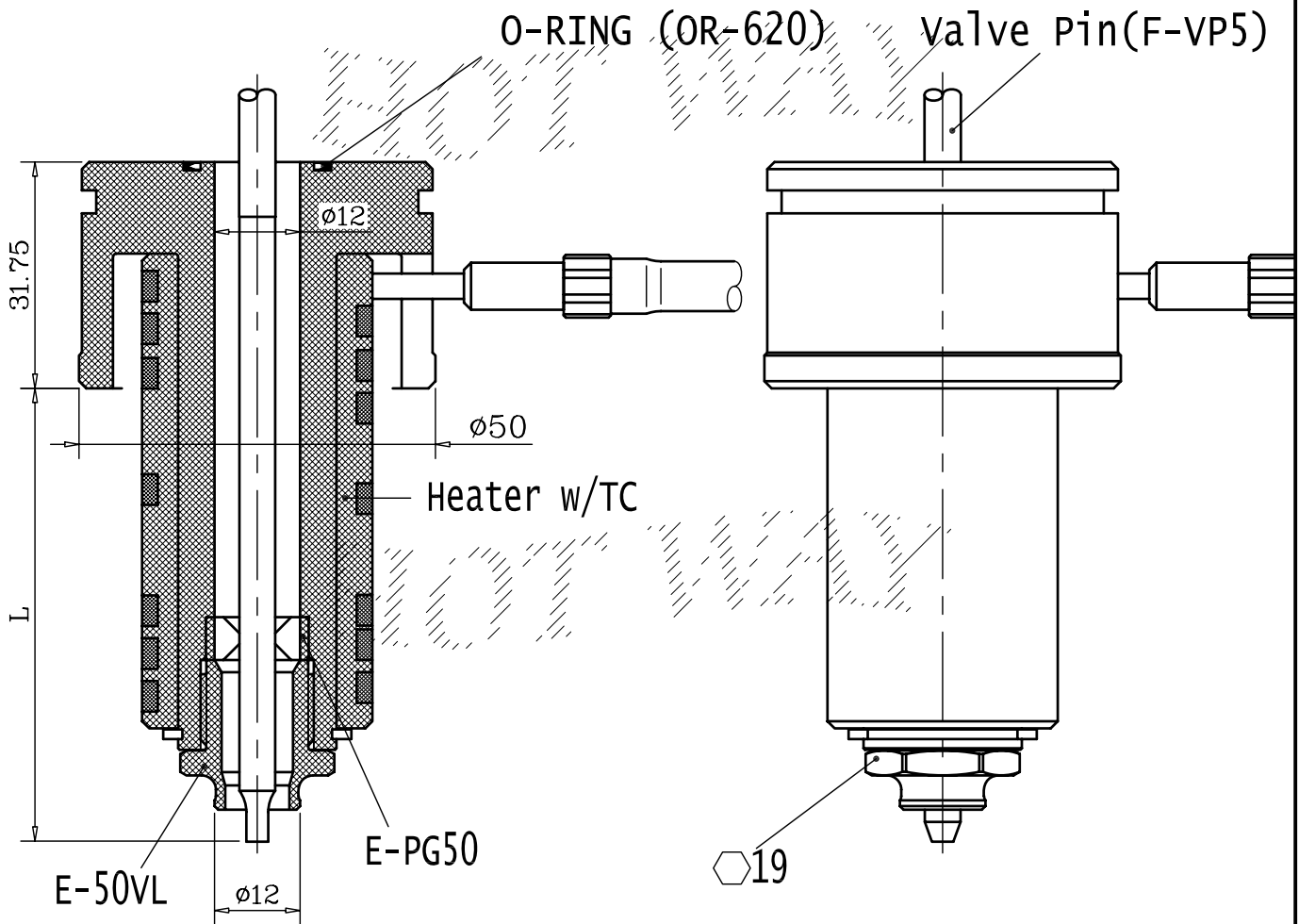

Shot weight (gm)	
High Flow	700
Medium Flow	500
Low Flow	200

Nozzle Part No	L(mm)	Heater Part No	Wattage
HTM-5020VL	50.8	CH-5020	450W
HTM-5025VL	63.5	CH-5025	450W
HTM-5030VL	76.2	CH-5030	600W
HTM-5035VL	88.9	CH-5035	600W
HTM-5040VL	101.6	CH-5040	700W
HTM-5050VL	127.0	CH-5050	700W
HTM-5060VL	152.4	CH-5060	800W

# SERIES 50 VL-TYPE

## VALVE GATE

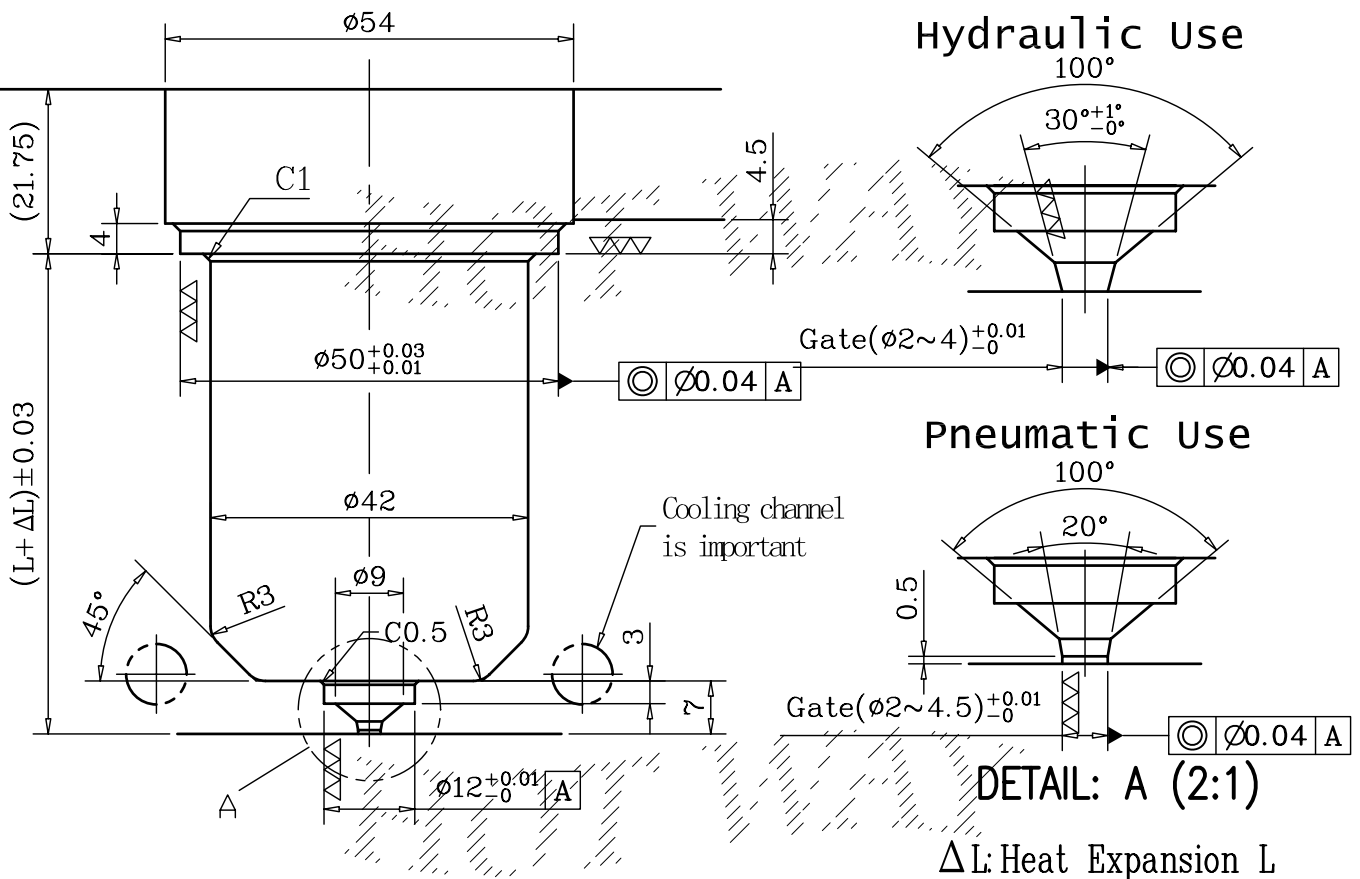
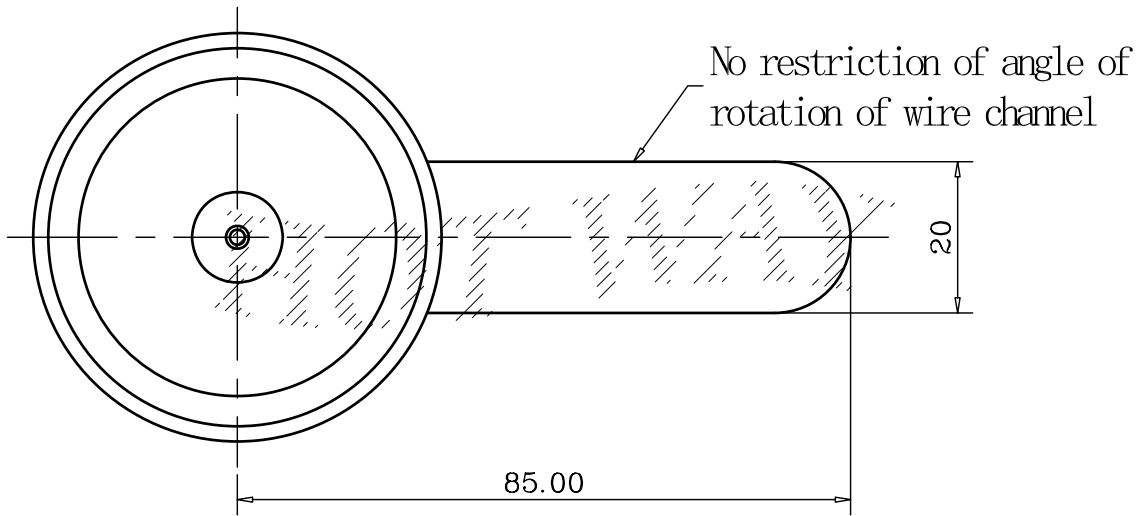

Nozzle Part No	L(mm)	L+ ΔL			
		150 °C	200 °C	250 °C	300 °C
HTM-5020VL	50.8	50.90	50.93	50.97	51.00
HTM-5025VL	63.5	63.63	63.67	63.71	63.75
HTM-5030VL	76.2	76.35	76.40	76.45	76.50
HTM-5035VL	88.9	89.08	89.13	89.19	89.25
HTM-5040VL	101.6	101.80	101.87	101.94	102.00
HTM-5050VL	127.0	127.25	127.34	127.42	127.50
HTM-5060VL	152.4	152.70	152.80	152.90	153.00